



## PRODUCT INFO

DESIGNATION  
heliflex iceflex

PRODUCT CODE  
302 015

MATERIALS  
Flexible PVC reinforced with rigid PVC spiral.

STANDARDS  
Manufactured according to ISO 3994 standard.

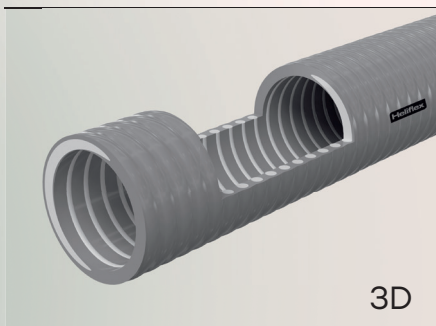

3D

## TECHNICAL FEATURES

Abrasion resistance; Medium resistance to vacuum pressure; Resistance to low temperatures.



## increase toughness and minimize problems

### Description

Opaque hose, highly flexible, reinforced with a rigid PVC spiral, suitable for low-temperature environments. Used for conveying water, chemical solutions, and abrasive solids. Manufactured according to ISO 3994 standards.

#### Application Areas:

Transporte de água, algumas soluções químicas e sólidos abrasivos. Agricultural use; Water conveyance; Domestic use.

#### Main features:

Opaque hose, flexible, reinforced with a rigid PVC spiral, used in negative temperatures ambient.

#### Temperature:

-30/+50°C

#### Presentation:

Colour: Grey

Available in lengths of 20, 25, 30 and 50 metres, depending on the diameters.\*

Other colours, diameters and lengths available upon request.

#### Marking:

**Heliflex** heliflex iceflex Ømm lote data



heliflex iceflex | 302 015

CODE				OUTER Ø	THICKNESS	WEIGHT	WORK PRESSURE	BURST PRESSURE	VACUUM	BEND RADIUS		
GROUP	INNER Ø	LENGTH	COLOR									
	mm	m		mm	mm	kg/m		bar	bar	mm		
302 015	025	*	62	32,8	3,9	0,430	7,0	22,0	0,9	125		
	032	*		40,6	4,3	0,720				5,0	16,0	135
	038	*		47,0	4,5	0,750						140
	040	*		47,0	4,5	0,750	140					
	050	*		61,2	5,6	1,150	15,0	170				
	051	*		62,0	5,5	1,170		170				
	060	*		71,6	5,8	1,300		190				
	063	*		73,0	5,0	1,350	4,1	13,0		198		
	075	*		86,8	5,9	1,730				240		
	076	*		89,0	6,3	1,740				240		
	090	*		102,0	6,0	2,150	3,8	12,0		290		
	100	*		113,0	6,5	2,680				320		
	102	*		115,0		2,700				320		
	120	*		135,8	7,4	3,500	3,2	10,0		376		
	125	*		139,0	7,0	3,700				570		
	127	*		142,2	7,6	3,800				580		
	150	*		166,0	8,5	5,000	2,5	8,0		600		
	152	*		166,4		5,100				608		
200	*	222,4	10,6	8,600	2,0	6,0	800					

